

REMOVAL

1. DISCONNECT CABLE FROM NEGATIVE BATTERY TERMINAL
2. REMOVE NO. 1 ENGINE UNDER COVER SUB-ASSEMBLY (See page EM-6)
3. REMOVE FAN AND GENERATOR V BELT (See page EM-6)
4. DRAIN POWER STEERING FLUID
5. DISCONNECT NO. 1 OIL RESERVOIR TO PUMP HOSE

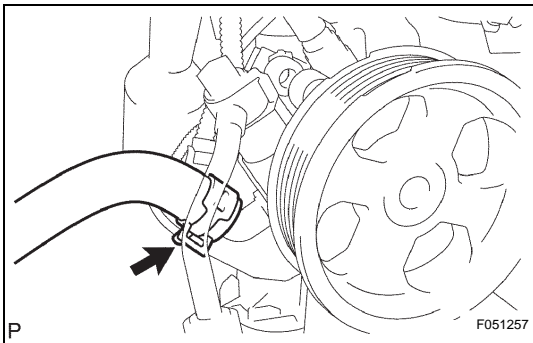

- (a) Disengage the clip and disconnect the No. 1 oil reservoir to pump hose.

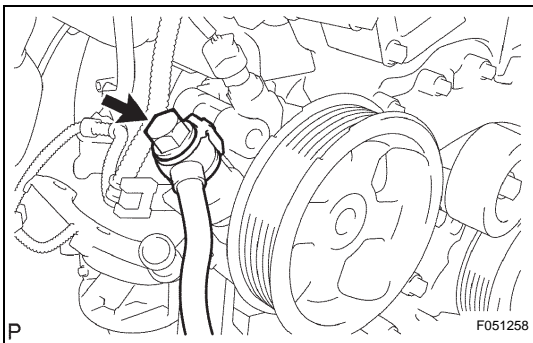

6. DISCONNECT PRESSURE FEED TUBE ASSEMBLY
 - (a) Remove the union bolt, then disconnect the pressure feed tube.
 - (b) Remove the gasket from the pressure feed tube.

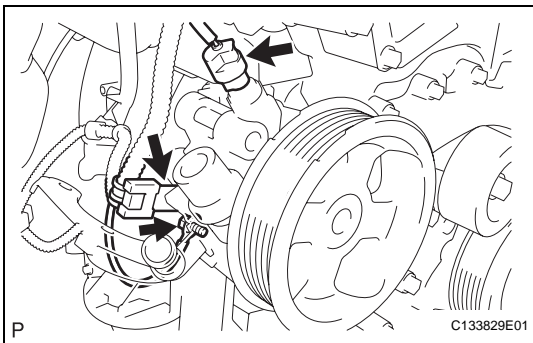

7. REMOVE VANE PUMP
 - (a) Disconnect the oil pressure switch connector.
 - (b) Remove the bolt and the wire harness clamp bracket.

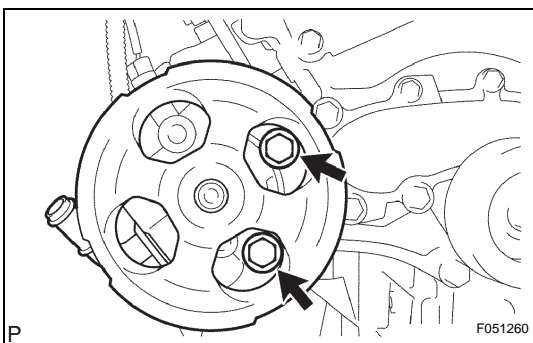

- (c) Remove the 2 bolts and the vane pump assembly.

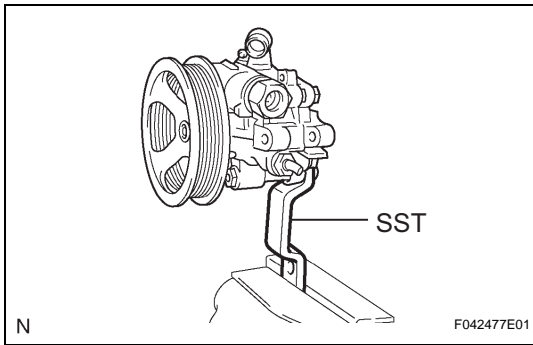

DISASSEMBLY

1. FIX VANE PUMP

- (a) Using SST, fix the vane pump assembly in a vise.
SST 09630-00014 (09631-00132)

NOTICE:

Do not over tighten the vise.

2. REMOVE POWER STEERING SUCTION PORT UNION

- (a) Remove the bolt and suction port union.
(b) Remove the O-ring from the suction port union.

3. REMOVE FLOW CONTROL VALVE

- (a) Remove the pressure port union.
(b) Remove the O-ring from the pressure port union.
(c) Remove the flow control valve and compression spring.

4. REMOVE POWER STEERING OIL PRESSURE SWITCH

NOTICE:

Be careful not to drop or badly damage the oil pressure switch. If damaged, replace it with a new one.

5. REMOVE VANE PUMP REAR HOUSING

- (a) Remove the 4 bolts and vane pump housing rear from the vane pump housing front.
(b) Remove the O-ring from the vane pump housing front.

6. REMOVE PULLEY SHAFT SUB-ASSEMBLY

NOTICE:

Be careful not to drop or badly damage the pulley shaft. If damaged, replace it with a new one.

- (a) Using a screwdriver, remove the snap ring from the pulley shaft.
(b) Remove the pulley shaft.

7. REMOVE VANE PUMP ROTOR

- (a) Remove the 10 vane plates.
(b) Remove the vane pump rotor.

8. REMOVE VANE PUMP CAM RING

9. REMOVE VANE PUMP FRONT SIDE PLATE

- (a) Remove the side plate from the vane pump housing front.
(b) Remove the O-ring from the side plate.

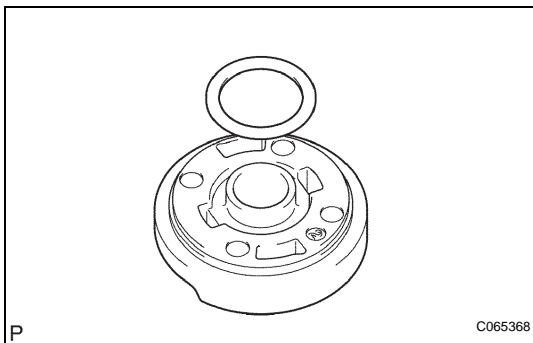

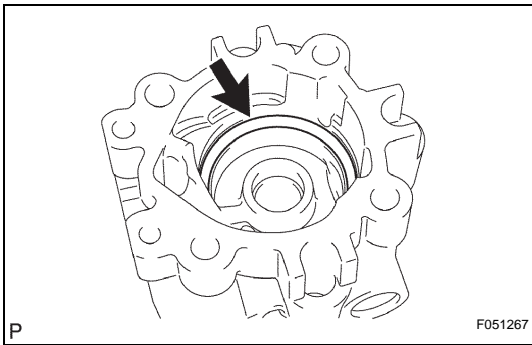

- (c) Remove the O-ring from the vane pump housing front.

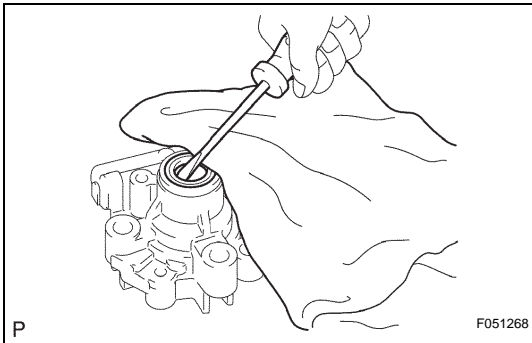

10. REMOVE VANE PUMP HOUSING OIL SEAL

- (a) Using screwdriver, remove the oil seal.

NOTICE:

Be careful not to damage the vane pump housing front.

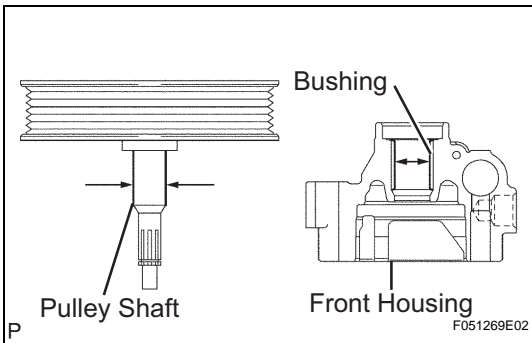

INSPECTION

1. INSPECT OIL CLEARANCE

- (a) Using a micrometer and caliper gauge, measure the oil seal clearance.

Standard clearance:

0.021 to 0.043 mm (0.0008 to 0.0017 in.)

Maximum clearance:

0.07 mm (0.0028 in.)

If it is greater than the maximum, replace the vane pump assembly.

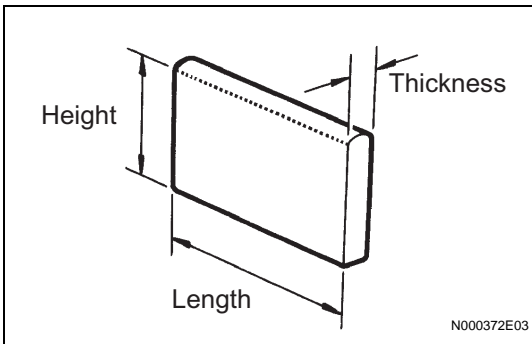

2. INSPECT VANE PUMP ROTOR AND VANE PUMP PLATE

- (a) Using a micrometer, measure the height, thickness and length of the vane plates.

Minimum height:

7.6 mm (0.299 in.)

Minimum thickness:

1.405 mm (0.0553 in.)

Minimum length:

11.993 mm (0.4722 in.)

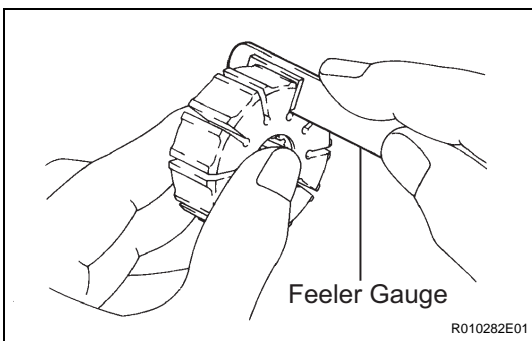

- (b) Using a feeler gauge, measure the clearance between a side face of the vane pump rotor groove and vane plate.

Maximum clearance:

0.025 mm (0.0010 in.)

If it is greater than the maximum, replace the vane pump assembly.

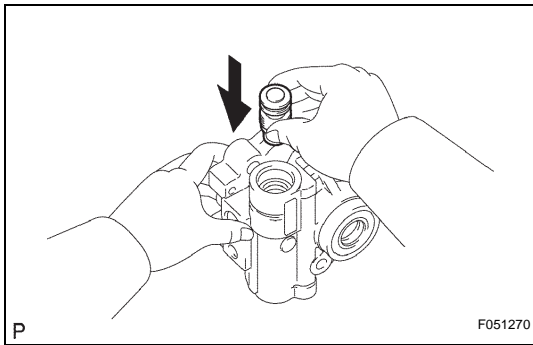

3. INSPECT FLOW CONTROL VALVE

- (a) Coat the flow control valve with power steering fluid and check that it falls smoothly into the flow control valve hole under its own weight.

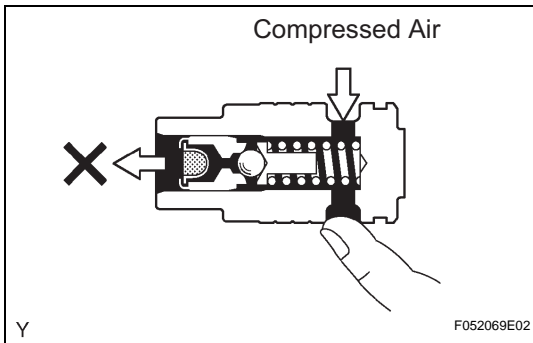

- (b) Check the flow control valve for leakage. Close one of the holes and apply compressed air of 392 to 490 kPa (4 to 5 kgf/cm², 57 to 71 psi) to the hole on the opposite side. Confirm that the air does not flow out from the end holes.

If necessary, replace the vane pump assembly.

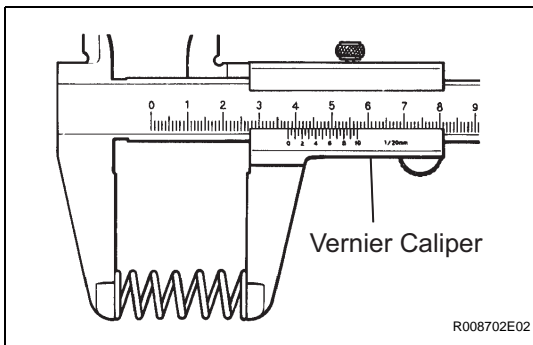

4. INSPECT COMPRESSION SPRING

- (a) Using vernier calipers, measure the free length of the spring.

Minimum free length:

29.2 mm (1.150 in.)

If it is not within the specification, replace the vane pump assembly.

5. INSPECT PRESSURE PORT UNION SUB-ASSEMBLY

- (a) If the union seat in the pressure port union is badly damaged, it could cause fluid leakage, so replace the vane pump assembly.